

## Einschweisdehner Typ PD, nicht feststellbar

*Welding expansion piece type PD, not lockable*

*Pièce de dilatation type PD, non-autobuté*

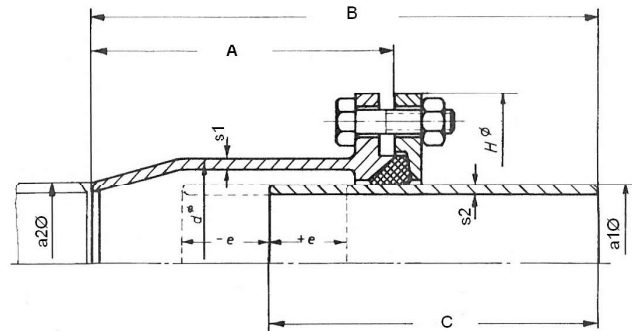

DN	PN 10				Verstellbarkeit +/- e in mm	Profil
	kg	a1Ø bzw. a2Ø	Maß in mm			
			B	H Ø		
50	10		880	160	200	P1
65	13		880	185	200	P1
80	17		880	210	200	P1
100	22		890	225	200	P2
125	24		890	240	200	P2
150	37		890	290	200	P2
200	46		890	330	200	P2
<b>250</b>	<b>85</b>	<b>Ø273x8</b>	<b>900</b>	<b>415</b>	<b>200</b>	<b>P3</b>
<b>300</b>	<b>98</b>	<b>Ø323,9x8</b>	<b>900</b>	<b>460</b>	<b>200</b>	<b>P3</b>
350	103		900	485	200	P3
400	120		960	540	200	P3
450	129		960	585	200	P3
<b>500</b>	<b>133</b>	<b>Ø508x6</b>	<b>960</b>	<b>655</b>	<b>200</b>	<b>P3</b>
<b>600</b>	<b>175</b>	<b>Ø610x6</b>	<b>960</b>	<b>770</b>	<b>200</b>	<b>P4</b>
700	260		960	855	200	P4
800	304		980	960	200	P4
900	340		980	1060	200	P4
1000	375		980	1160	200	P4
1200	468		990	1395	200	P5
<b>1300</b>	<b>646</b>	<b>Ø1320x12</b>	<b>1000</b>	<b>1510</b>	<b>200</b>	<b>P5</b>
<b>1400</b>	<b>619</b>	<b>Ø1420x10</b>	<b>1030</b>	<b>1610</b>	<b>200</b>	<b>P5</b>
<b>1600</b>	<b>713</b>	<b>Ø1624x10</b>	<b>1050</b>	<b>1624</b>	<b>200</b>	<b>P5</b>
1800	1315		1060	2020	200	P5
2000	1490		1110	2220	200	P5

Technische Änderungen und Irrtümer vorbehalten / technical changes and errors reserve

## Einschweisdehner Typ PD, nicht feststellbar

*Welding expansion piece type PD, not lockable*

*Pièce de dilatation type PD, non-autobuté*

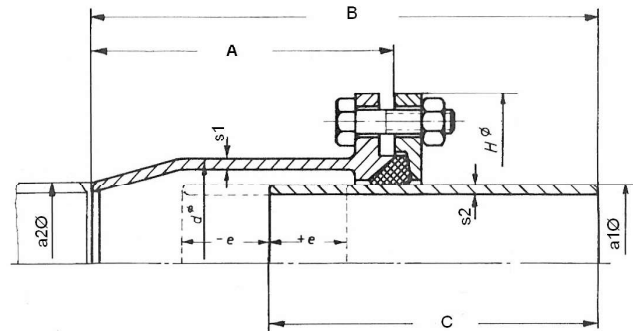

DN	PN 16				Verstellbarkeit +/- e in mm	Profil
	kg	a1Ø bzw. a2Ø	Maß in mm			
			B	H Ø		
50	10		880	160	200	P1
65	13		880	185	200	P1
80	17		880	210	200	P1
100	22		890	225	200	P2
125	24		890	240	200	P2
150	37		890	290	200	P2
200	46		890	330	200	P2
250	68		900	395	200	P3
300	86		900	445	200	P3
350	108		900	485	200	P3
400	130		960	540	200	P3
450	142		960	585	200	P3
500	154		960	635	200	P3
600	233		960	755	200	P4
700	274		960	855	200	P4
800	322		980	960	200	P4
900	394		980	1060	200	P4
1000	436		980	1160	200	P4
<b>1200</b>	<b>524</b>	<b>Ø1220x10</b>	<b>990</b>	<b>1410</b>	<b>200</b>	<b>P5</b>
<b>1300</b>	<b>646</b>	<b>Ø1320x12</b>	<b>1000</b>	<b>1510</b>	<b>200</b>	<b>P5</b>
1400	864		1030	1600	200	P5
1600	1136		1050	1800	200	P5
1800	1530		1060	2020	200	P5
2000	1740		1110	2220	200	P5

Technische Änderungen und Irrtümer vorbehalten / technical changes and errors reserve